

Inquiry on the Submission Progress

Kotak Masuk

- **tomoliyus** <tomoliyus@uny.ac.id>

18 Apr
2018
14.51

ke ICIBSOS

I have submitted my revised manuscript entitled 'Developing design and construction of backspin serving skill tests to assess the learning outcomes for table tennis serving skills' (15 February 2018) and also have sent the CTF and PVF signed by the authors (17 February 2018) to ICIBSOS 2017 via email.

However, I have not received any information regarding the progress of the manuscript ever since.

Thus, I would be grateful if you could let me know whether there has been any further progress on my submission.

Thank you.

Sincerely,
Tomoliyus

ICIBSOS Conf <icibsoconf@gmail.com>

19 Apr
2018
13.53

ke saya

Dear Dr Tomoliyus

Thank you very much for your email.

The Proceedings of ICIBSoS 2017 is in this link

<https://www.crcpress.com/Issues-and-Trends-in-Interdisciplinary-Behavior-and-Social-Science-Proceedings/Gaol/p/book/9781138553804>

It will be go alive at the end of May 2018

Revision in Word and Pdf, and Certificate of Language Editing

Kotak Masuk

- tomoliyus <tomoliyus@uny.ac.id>

Kam, 15 Feb
2018 16.27

ke ICIBSOS

Dear ICIBSoS 2018

I herewith enclose my revised manuscript and its editing certificate from one of your recommended editing services.

Thank you.

Best regards,
Tomoliyus

Developing design and construction of backspin serving skill tests to assess the learning outcomes for table tennis serving skills

Sumaryanti¹, Tomoliyus², Sujarwo³, Bandi Utama⁴, Herka Maya Jatmika⁵

Faculty of Sports Sciences, Yogyakarta State University, Indonesia^{1,2,3,4,5}

ABSTRACT: The purpose of this study was to develop and design backspin serving skill tests to assess the learning outcomes of table tennis serving skills. The study employed the following research and development methods: (1) Developing the design and construction of backspin serving skill tests and testing the content validity of the design and construction of the backspin serving skills of table tennis game, (2) Searching for empirical validity and reliability of the backspin serving skill tests. The subjects of the study were students studying table tennis. The data analysis involved content validity ratios, product moment formulas and Cronbach's Alpha formula. We showed that (1) the content validity of the test was high (content validity ratio= 0.90) with the design and construction of three target marks on the table: the first area (152.5 cm x 35 cm) was scored 5, the second (152.5 cm x 35 cm) was scored 3, and the third area (152.5 cm x 67 cm) was scored 1 with a string set across the table 20 cm above the net. This string was attached according to the procedures of the test and scoring guide, (2) the empirical validity was 0.893, and the reliability was 0.938 for students studying table tennis serving. The design and construction of this backhand serving test can be used to assess learning outcomes of table tennis serving skills.

1. InTroduction

Serving is a technique that is important and must be controlled by a table tennis player (Liu, 2010); (Flores, Bercades, & Florendo, 2010); (Kasai & Mori, 1992); (Hirst, 1999). Good serving skill produces precision targeting areas which the opponent finds difficult to accepted

or return (Tomoliyus, 2011). When learning backspin service skills, one must keep in mind the way that the ball backspins slightly above the net, bounces on the server's side near the net with the second bounce on receiver's side close to the baseline (Tepper, 2005); (Aaron & Derek, nd). Richard (2009) stated that a target ball that is difficult to accept or return by the opponent is in the area near the net, as well those with a low ball bounce on the opponent's table. In other words, the results of serving targets that are difficult to accept or be returned by the recipient are the targets that are away from the opponent, either forwards, sideways, or to the right side of the recipient.

Based on the ball spins, there are three types of service, namely, round to the back (backspin), round to the front (topspin) and round to the side (sidespin). The technique of forehand and backhand serving includes the following: the left foot is positioned at the front, and the body slightly leans toward the table (for right-handed players), the arms position form a small corner with the arm pointing downwards. The position of bet is open when serving (Richard, 2009), turning side to the target, keeping the eyes on the ball and hitting the ball into the table at a 45-degree angle (Harrison & McCurdy, nd.). Open bet means, when hitting the ball, the front bet position is facing forward, the movement of serving with an open bet position is performed from top to bottom, resulting in backspin on the ball. Meanwhile, the serving motion with an open bet position from right to left or from left to right will produce a sidespin ball (Iizuka, Ushiyama, Yoshida, Fei, Yu, & Kamijima, 2010). Serving movement with bet open position from the rear to the front is used to create a slight backspin ball. Serving movements with a closed position bet from the rear to the front produces a topspin ball. Low arm ends the movement before the forehead. Therefore, for making a stroke, low arms form a smaller angle.

To be able to master table tennis serving, students require good learning techniques. Good learning and teaching process generate good ratings, and good judgment encourages students' learning outcomes. Good assessment of learning outcomes can be achieved by employing a good test and determining whether the test is valid and reliable.

Assessment of learning outcomes of backspin serving skills of table tennis games requires valid and reliable tests. Currently, there is a test to assess table tennis backspin serving, but the design and construction of the test still needs to be improved. Thus, the authors wanted to investigate and develop a test aimed at (1) developing skill competencies for backspin serving in table tennis (content validity), (2) testing the empirical validity and the reliability of the backspin serving skill test.

Based on the theory and objectives of the research, the research hypotheses were the following: (1) the design and construction of table tennis backspin serving test should have high content validity, and (2) the design and construction of the backspin serving skill test should have high empirical validity and reliability.

Validity and reliability are the basic requirements for measuring devices or tests to be developed or designed (Arifin, 2012); (Sukardi, 2009). Validity is the precision of a test to measure the aspects that should be measured. Tests that are valid for a specific purpose may not be valid for any other purpose. Therefore, validity is always associated with a specific purpose. The validity of the measurement is scored from low to high. The higher the level of validity is, the better the measurement is.

Baumgartner et al. (2007) generally divides validity in two groups, namely, rational validity and empirical validity. Rational, or content, validity is referred to as internal validity because it shows that a suitable test has to measure the contents of that which will be measured. Content validity relates to the ability of an instrument to measure the content (concept) to be measured. This means that a measuring instrument should be able to reveal the content of a

concept or variable to be measured. Content validity is calculated by testing the validity of the content using a measuring instrument with rational analysis of an expert.

Meanwhile, the empirical, or external, validity (also called criterion-related validity) is the validation of an instrument by comparing it with other measurement instruments that are valid and reliable through correlations. When the correlation is significant, the instrument is considered to have the criteria validity. A criterion validity-based approach requires the availability of external criteria that can be used as a basic test for a measurement instrument score. A criterion is a variable behavior to be predicted by a measuring instrument score. To see criterion-based validity, we can use a computation of correlations between the measurement instruments scores with the criteria scores. This coefficient constitutes a validity coefficient for the measuring instrument designed, namely, r_{xy} , where x is the measuring instruments score, and y is the criteria scores (Arifin, 2012).

According to Sugiono (2007), reliability is a series of measurements or series of gauges that have consistency if the conducted measurement using that instrument are performed repeatedly. Reliability of the test is the degree of regularity or consistency of a test, namely, the extent to which a test can be trusted to produce a score that is steady and relatively unchanged although it is tested in different situations. Reliability can be obtained via test-retest. This testing is performed using the instruments twice on same respondents. In this case, the instrument and respondents should be the same, but the timing would be different. Reliability was obtained by differentiating the first test-second test, calculated with Cronbach's Alpha. If the alpha value is between 0.80 and 1.00, then the reliability is very high.

2. METHODS

This study employed research and development, with the first two stages to test the content validity of the design and construction of backspin serving skills tests; the second phase was to test the validity and reliability of the design and construction of the empirical backspin serving skills tests. The research subjects were beginner table tennis athletes. Techniques to search for content validity used seven experts in Focus Group Discussion (FGD) and the Delphi technique. Empirical validity was obtained through correlating the serving skill tests with the rating score from the seven experts due to the serving techniques used, looking for reliability by means of correlating the first test and the second test. The researchers analyzed data for content validity using the Content Validity Ratio (Wilson, Pan, & Schumsky, 2012). Empirical validity was tested using the product moment formula, and reliability was tested using Cronbach's Alpha formula.

3. RESULTS

The design and construction of backspin serving skill tests was assessed by seven table tennis experts by means of Focus Group Discussion (FGD) and Delphi techniques. Next, the results of the assessment of seven experts were calculated by a formula of content validity ratio (CVR). The design and construction of table tennis backspin serving skill tests generated a CVR value = 0.90. The design and construction of the table tennis backspin serving skill test was developed to have high content validity. This finding means that the developed test instrument was contested, and the construction tests showed a linear or accurate skill relevant to the ability of serving in table tennis. Therefore, the design and construction of table tennis backspin serving skill tests in this research was eligible to test its empirical validity. The details for the test design and construction of table tennis backspin serving skill tests were as follows: The purpose of the test was to measure the ability of serving backspin. The equipment was a table tennis ball, paddle, rope, and scoreboard. The signs table included signs for the three targets, namely, score 1, with the size of 152.5 cm x 35 cm, score 2 with the size of 152.5 cm x 35 cm, and score 3 with the size of 152.5 cm x 67 cm. Distance from rope to the net was 20 cm; the table was marked with the targets as seen in figure 1. Test

instruction was as follows: the subject was asked to warm up and practice sufficiently. The subject made backspin serve towards the targets, in which the ball passes under the rope. Next, the subject serves 10 times toward the target at the right and 10 times toward the target at the left side in turns. The scoring direction was as follows: scoring carried out by two people. The first person acted as the registrar, and the second person watched the ball which was served passing under the rope and reach the target. Scores were obtained by adding the target points of the serving as many as 20 times.

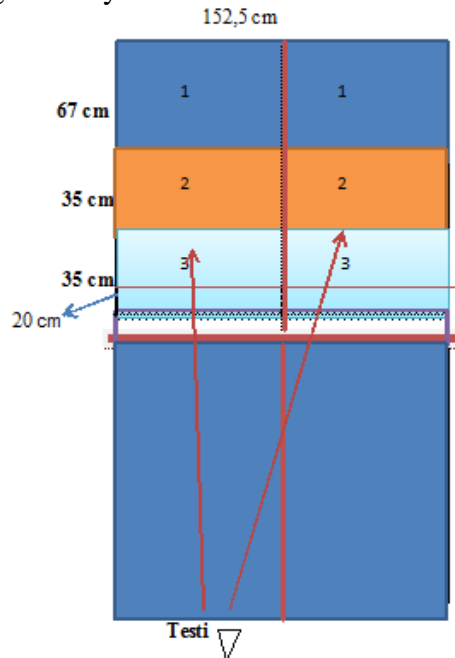

Figure 1: Target signs on the table with the score on it.

The empirical validity results were gained by means of correlating the score results of the backspin serving skill tests (BS2T) and assessment score from the serving techniques experts (STE), which will be used as the criteria. The results correlation results are as shown in Table 1.

Table 1. Score results of the backspin serving skill tests (BS2T) and assessment score from the serving techniques experts (STE)

	BS2T	STE
Pearson	1	0.893
BS2T Correlation		
Sig. (2-tailed)		0.000
N	25	25
STE Pearson		
Correlation	0.893	1
Sig. (2-tailed)	0.000	
N	25	25

Table 1 shows the results of correlation between the backspin serving skill tests (BS2T) and of assessment score from the serving techniques experts (STE). The coefficient of correlation between serving skill test and assessment score from the experts amounted to $r_{xy} = 0.893$. Based on the 0.01 significance level, $r_{xy} = 0.893 > r_{table} = 0.505$. H_1 is accepted, and H_0 is

rejected. The design and construction of the table tennis backspin serving skill test developed had high empirical validity.

The reliability test results were obtained by differentiating the first test scores and second test score of the backspin serving skill tests with the same respondents, but the timing was different. The reliability test results are shown in Table 2.

Table 2. Results of reliability test.

Cronbach's Alpha	N of Items
0.938	2

Table 2 shows the results of the reliability test between test1 and test2 score is Cronbach's Alpha 0.938. The design and construction of the table tennis backspin serving skill test developed had high reliability. In other words, the test showed a degree of stable measurements made over time (stability over time).

4. DISCUSSION

The main requirement of measuring devices or test development is validity and reliability (Arifin, 2012); (Sukardi, 2013). In general, validity consists of two levels, namely, rational validity or content validity and empirical validity (Baumgartner et al., 2007). Validity of the content is obtained by employing FGD with some experts and/or using the Delphi technique. Meanwhile, the empirical validity is obtained by way of correlating between the scores of measurement instruments with the score of criteria. Meanwhile, reliability can be gained by correlating the first test and the second test with the same respondents, but with different timing (Sugiono, 2007). Based on the test development requirements above, the development conditions of construction test of backspin serving skill in table tennis must be valid and reliable. The results of this study showed that the content validity of the construction test development of backspin serving skill or content validity ratio (CVR) was 0.90. Thus, this tool of measuring service accuracy developed in this research was scientifically demonstrated to determine the target area close to the net, and produced a low ball-bounce that was difficult to accept or be returned by the opponent. This is in accordance with the opinion of Tomoliyus (2016) and Richard (2009), who stated that the goals or targets that are difficult to be received or returned by the opponent are in the area near the net, with the low bouncing ball in the opponent area. Therefore, this test can be used to test its empirical validity.

Empirical validity was sought by looking for correlations between the construction test scores of backspin servings kills with the serving technique assessment as the criterion. The result was a correlation coefficient score between the first test scores and second test score of 0.898. This finding indicated that the level of accuracy or appropriateness of the instruments used to measure the skills of serving in this research was very high. According to Guilford and Benjamin (1977), a value of the correlation coefficient between 0.80 until 1.00 has very high validity. Therefore, we can say that this construction test of the backspin serving skill has very high empirical validity. In other words, this test has the feasibility and accuracy to measure the skills of table tennis backspin serve.

Furthermore, reliability was obtained by checking the first test with the second test with the same respondent, but with different timing. The results of the variability test showed that the

value of Cronbach's Alpha was 0.938. This finding showed that the level of reliability, constancy, consistency, and stability of measurements made over time was very high.

This result is in accordance with the opinion of Hair et al. (2010: 125), which stated that the value Cronbach's Alpha between 0.80 until 1.00 was very reliable. Therefore, the design and construction of the backspin serving skills test in table tennis has very high reliability. The design and construction of the backspin serving test developed has more accurate competency than the design and construction that has been previously available, because the design and construction in this test provided a limit line 20 cm above the net in order to let the ball pass between the net and the string. This finding is in line with the results of Tepper (2005) and Aaron and Derek, (nd.) who stated that learning backspin serving skills requires keeping in mind that the ball should have backspin slightly above the net, bounce on the server's side near the net, and bounce twice on the receiver's side, close to the baseline.

5. CONCLUSIONS

Based on the results and the discussion above, the following can be concluded:

The design and construction of table tennis backspin serving skill tests had high content validity. Next, the test instruments were in accordance with linear competency and are appropriate for learning the backspin serving skill.

The design and construction of the table tennis backspin serving skill test had very high empirical validity, exhibiting a coefficient value of 0.893, and very high reliability, exhibiting a value of 0.938. Thus, the test as feasible to use because it had measurement accuracy and consistency or regularity that may be applied repeatedly by the same respondents, but in a different time when performing backspin serving to measure skills.

A comparison has been made between the design and construction of this developed table tennis backspin skills test with the existing table tennis skill backspin test. The design and construction of this table tennis backspin serving test has a limit as to the path of the ball from the net height to the 20 cm rope. The test subject is forced to carry out a service wherein ball passes slightly (maximum 20 centimeters) above the net. When the ball passes over the rope, it is considered invalid. The difficulty in serving occurs when the ball bounces on the server side near the net and bounces twice on the side of the receiver, and the ball must be close to the baseline. This test is more appropriate than the existing test to measure the competence of backspin serving skills for table tennis.

5. ACKNOWLEDGMENTS

This work was supported by the Faculty of Sport Science, Yogyakarta State University and the Indonesian Table Tennis Association.

REFERENCES

- Aaron, H. & Derek, D. nd. Table tennis. Accessed on 30 July 2017. [web.uvic.ca/~thopper/Pe352/2002/Table Tennis8DerekAaron.pdf](http://web.uvic.ca/~thopper/Pe352/2002/Table%20Tennis8DerekAaron.pdf)
- Arifin, Z. 2012. *Evaluasi Pembelajaran*. Bandung: PT. Remaja Rosdakarya.
- Baumgartner, T.A., Jackson, A.S., Mahar, M.T., & Rowe, D.A. 2007. *Measurement for Evaluation in Physical Education and Exercise Science*, New York: Mc Graw Hill.
- Flores, M.A., Bercades, D., & Florendo, F. 2010. Effectiveness of Shadow Practice in Learning the Standard Table Tennis Backhand Drive. *International Journal of Table Tennis Sciences*, no.6: 46.
- Guilford & Benjamin Fruchter.1977. *Fundamental Statistics in Psychology and Education*, New York: McGraw-Hill Book Co.
- Hair, Joseph F., et.al. 2010. *Multivariate Data Analysis, 7th Edition*. New York: Prentice Hall International, Inc.

- Harrison, J. & McCurdy, N. nd. Table tennis. Accessed on 30 July 2017. http://www.pelinks4u.org/naspeforum/discus/messages/1239/Table_Tennis_Harrison_McCurdy-2784.pdf
- Hirst, P.A. 1999. Table tennis. Accessed on 30 July 2017. www.teachpe.com/gcse/Table%20Tennis.pdf.
- Iizuka S., Ushiyama, Y., Yoshida, K., Fei, Y., Yu, Z.H., & Kamijima, K. 2010. The Measuring Ball Spin at the Service in Table Tennis by Junior player. *International Journal of Table Tennis Sciences*, no.6: 122.
- Kasai, J. & Mori, T. 1992. Studies of various strokes in table tennis. *International Journal of Table Tennis Sciences*, no.1: 39.
- Liu, K. 2010. Reasons for the defeat of Wang Hao in table tennis men's singles final of Beijing Olympic Games from the technical and tactical point of view. *Journal of Shandong Institute of Physical Education and Sports*, 5: 73-76.
- Richard Mc Afee. 2009. *Table Tennis Step to Success*. United States: Human Kinetics.
- Sugiyono. 2007. *Metode Penelitian Pendidikan. Pendekatan kuantitatif, kualitatif dan R & D*. Bandung: Alfabeta.
- Sukardi. 2009. *Metodologi penelitian pendidikan: kompetensi dan praktiknya* Jakarta: Bumi Aksara.
- Tepper, G. 2005. ITTF Coaching Manual Level 1.As cited in USA. *Table Tennis Magazine*, vol.76: 3.
- Tomoliyus, Sumaryanti & Jadmika, H.M. 2016. Development of Validity and Reliability of Net Game Performance-Based Assessment on Elementary Students' Achievement in Physical Education. *International Journal of Assessment and Evaluation in Education*, vol. 6, no.1: 41 - 49.
- Wilson, F., Pan, W., & Schumsky, D. 2012. Recalculation of the critical values for Lawshe's content validity ratio. *Measurement and Evaluation in Counseling and Development*, 45(3), 197-210 <http://dx.doi.org/10.1177/0748175612440286>.

 Taylor & Francis Group
an informa business

EDITING CERTIFICATE

This document certifies that the manuscript listed below was edited for proper English language, grammar, punctuation, spelling, and overall style by one or more of the highly qualified native English-speaking editors at Taylor & Francis Editing Services.

Manuscript title:
Developing design and construction of backspin serving skill tests to assess the learning outcomes for table tennis serving skills

Authors:
Sumaryanti, Tomoliyus, Sujarwo, Bandi Utama, Herka Maya Jatmika

Date Issued:
February 13, 2018

Certificate Verification Key:
102F-4F0C-A543-29F4-03F4

This certificate may be verified at secure.tandfedittingservices.com/certificate. This document certifies that the manuscript listed above was edited for proper English language, grammar, punctuation, spelling, and style by one or more of the highly qualified native English-speaking editors at Taylor & Francis Editing Services. Neither the research content nor the authors' intentions were altered in any way during the editing process. Documents receiving this certification should be English ready for publication; however, the author has the ability to accept or reject our suggestions and changes. To verify the final Taylor & Francis Editing Services edited version, please visit our verification page. If you have any questions or concerns about this edited document, please contact Taylor & Francis Editing Services at support@tandfedittingservices.com.

Taylor and Francis Proof Reading Result : 147

Kotak Masuk



ICIBSOS Conf <icibsosconf@gmail.com>

Rab, 7 Feb
2018 10.27

ke saya, tomoliyus, bandi_utama, sujarwo, sumaryanti, herka_mayajatmika

Dear Tomoliyus, Bandi Utama, Sujarwo, Sumaryanti, Herka Maya Jatmika,

We got the proof reading result from Taylor and Francis and confirm that your paper **MUST BE REVISED** in depth and serious for the English Translation and English Proof Reading.

We strongly suggest that you send your paper into the Professional English Proof reading Services such as :

<https://www.tandfeditingservices.com/en/>

<https://webshop.elsevier.com/languageservices/languageediting/>

<https://proofreading.org/>

<http://authorservices.springernature.com/language-editing/>

<https://authorservices.taylorandfrancis.com/checking-proofs/>

However you may also sent your paper to other Professional Proof Reading Services

This is the **LAST** and **FINAL** revision of your paper and in case there is **NO** significant revision in English and Proof Reading the Taylor and Francis will **REJECT** your paper for the publication on ICIBSoS 2017.

Please be noted that there is **NO** refund if your paper rejected by Taylor and Francis for the publication in ICIBSoS 2017.

We expected to have your Revision in Ms Word and pdf on the latest 20 Feb 2018 at 02:00 PM. Any delay for the submission will imply with the

reject result of your paper.

Best regards

ICIBSoS 2018



- tomoliyus <tomoliyus@uny.ac.id>

Rab, 14 Feb
2018 08.47

ke ICIBSOS

Thank you.
The language editing is in progress.
Is it still possible to change the order of the authors?



ICIBSOS Conf <icibsoconf@gmail.com>

Rab, 14 Feb
2018 10.35

ke tomoliyus, bandi_utama, sujarwo, sumaryanti, herka_mayajatmika, saya

Dear Tomoliyus, Bandi Utama, Sujarwo, Sumaryanti, Herka Maya Jatmika,

Thank you. Yes you may change the position of the authors.

Best regards

ICIBSoS 2018

On 2/14/18, - tomoliyus <tomoliyus@uny.ac.id> wrote:

- > Thank you.
- > The language editing is in progress.
- > Is it still possible to change the order of the authors?
- >

> 2018-02-07 10:27 GMT+07:00 ICIBSOS Conf <icibsosconf@gmail.com>:
>
>> Dear Tomoliyus, Bandi Utama, Sujarwo, Sumaryanti, Herka Maya Jatmika,
>>
>>
>>
>>
>>
>>
>>
>>
>>
>>
>>
>>
>>
>> We got the proof reading result from Taylor and Francis and confirm
>> that your paper MUST BE REVISED in depth and serious for the English
>> Translation and English Proof Reading.
>>
>>
>> We strongly suggest that you send your paper into the Professional
>> English Proof reading Services such as :
>>
>> <https://www.tandfedittingservices.com/en/>
>>
>> <https://webshop.elsevier.com/languageservices/languageediting/>
>>
>> <https://proofreading.org/>
>>
>> <http://authorservices.springernature.com/language-editing/>
>>
>> <https://authorservices.taylorandfrancis.com/checking-proofs/>
>>
>> However you may also sent your paper to other Professional Proof
>> Reading Services
>>
>>
>> This is the LAST and FINAL revision of your paper and in case there is
>> NO significant revision in English and Proof Reading the Taylor and
>> Francis will REJECT your paper for the publication on ICIBSoS 2017.
>>
>> Please be noted that there is NO refund if your paper rejected by
>> Taylor and Francis for the publication in ICIBSoS 2017.
>>
>> We expected to have your Revision in Ms Word and pdf on the latest 20
>> Feb 2018 at 02:00 PM. Any delay for the submission will imply with the
>> reject result of your paper.
>>
>>
>>
>>
>>

>>
>>
>> Best regards
>>
>>
>>
>>
>> ICIBSoS 2018
>>
>
> --
>
>
>
> -----
> Untuk mendukung “Gerakan UNY Hijau”, disarankan tidak mencetak email ini
> dan lampirannya.
> (To support the “Green UNY movement”, it is recommended not to print the
> contents of this email and its attachments)
> Universitas Negeri Yogyakarta
> www.uny.ac.id
> -----

REMINDER : Taylor and Francis Proof Reading Result : 147

Kotak Masuk



ICIBSOS Conf <icibsosconf@gmail.com>

Min, 11 Feb
2018 00.21

ke saya, tomoliyus, bandi_utama, sujarwo, sumaryanti, herka_mayajatmika

Dear Tomoliyus, Bandi Utama, Sujarwo, Sumaryanti, Herka Maya Jatmika,

On 07 Fe 2018 we already sent the Taylor and Francis Proof Reading Result of your paper with ID 147 as forwarded below.

Please provide acknowledgement that you already received it and provide with depth and serious for the English Translation and English Proof Reading.

Please be noted that there is NO refund if your paper rejected by Taylor and Francis for the publication in ICIBSoS 2017.

We expected to have your Revision in Ms Word and pdf on the latest 20 Feb 2018 at 02:00 PM. Any delay for the submission will imply with the

reject result of your paper.

Looking forward with your urgent response.

Best regards

ICIBSoS 2018

----- Forwarded message -----

From: ICIBSOS Conf <icibsosconf@gmail.com>

Date: Wed, 7 Feb 2018 10:27:19 +0700

Subject: Taylor and Francis Proof Reading Result : 147

To: tomoliyus@uny.ac.id, tomoliyus@yahoo.com, bandi_utama@uny.ac.id,
sujarwo@uny.ac.id, sumaryanti@uny.ac.id, herka_mayajatmika@uny.ac.id

Dear Tomoliyus, Bandi Utama, Sujarwo, Sumaryanti, Herka Maya Jatmika,

We got the proof reading result from Taylor and Francis and confirm that your paper **MUST BE REVISED** in depth and serious for the English Translation and English Proof Reading.

We strongly suggest that you send your paper into the Professional English Proof reading Services such as :

<https://www.tandfeditingservices.com/en/>

<https://webshop.elsevier.com/languageservices/languageediting/>

<https://proofreading.org/>

<http://authorservices.springernature.com/language-editing/>

<https://authorservices.taylorandfrancis.com/checking-proofs/>

However you may also sent your paper to other Professional Proof Reading Services

This is the LAST and FINAL revision of your paper and in case there is NO significant revision in English and Proof Reading the Taylor and Francis will REJECT your paper for the publication on ICIBSoS 2017.

Please be noted that there is NO refund if your paper rejected by Taylor and Francis for the publication in ICIBSoS 2017.

We expected to have your Revision in Ms Word and pdf on the latest 20 Feb 2018 at 02:00 PM. Any delay for the submission will imply with the reject result of your paper.

Best regards

ICIBSoS 2018